

<b>Protective Sliders (Crash Pads)</b>
<b>HYOSUNG GT 250 / 650 i Naked</b>

Year of production: ALL
-------------------------

Product code: 101101
----------------------

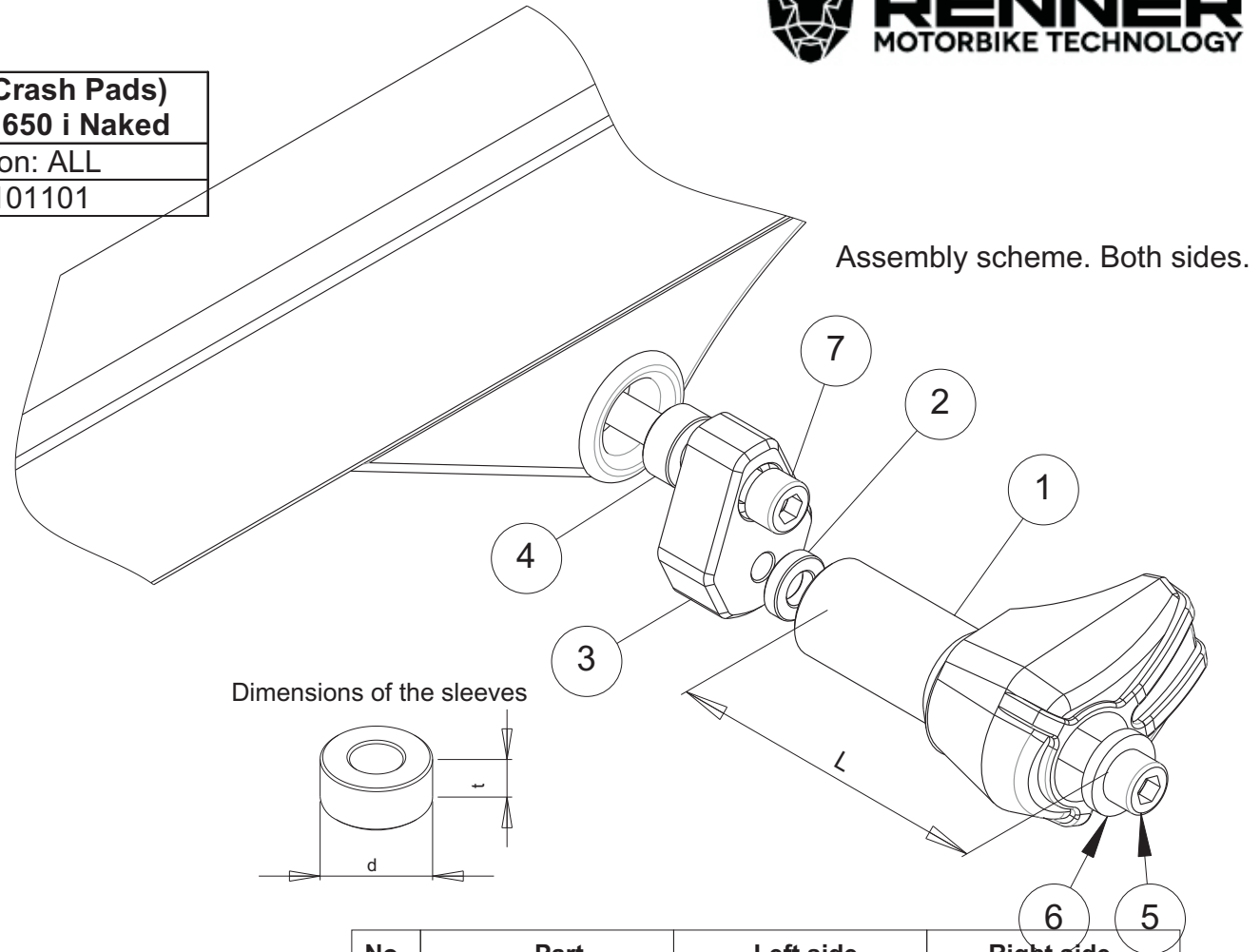

Assembly scheme. Both sides.

### Assembly instructions

1. Remove the engine screws indicated with the arrows.
2. Replace the removed screws by the new screws (parts #4) and metal bars (parts #2) according to the attached drawing. Put the metal parts (parts #2) in the right positions according to the drawing.
3. Assemble the sliders and the screws according to the drawing (parts #1, #6, #5).
4. Assemble the screws #5 and the sliders with the metal bars #2.

We suggest to use the threadlocker to make sure that the screws do not get loose.

This product is entirely produced in the European Union. This product is a professional accessory to be used on the race track. Renner LTD takes no responsibility for any damages occurred despite of using protective accessories. For more information go to [www.renner-moto.com](http://www.renner-moto.com)

No	Part	Left side	Right side
1	Slider	L = 80 mm	L = 105 mm
2	Sleeve	d=20 mm, t=5 mm	d=20 mm, t=5 mm
3	Bar		
4	Sleeve	d=20 mm,t=15 mm	D=20 mm,t=20 mm
5	Screw	M10	M10
6	Washer		
7	Main screw	M10, 70 mm	M10, 80 mm