

Protective sliders
SUZUKI GSR 600

Year of production: all
 Product code: 10310

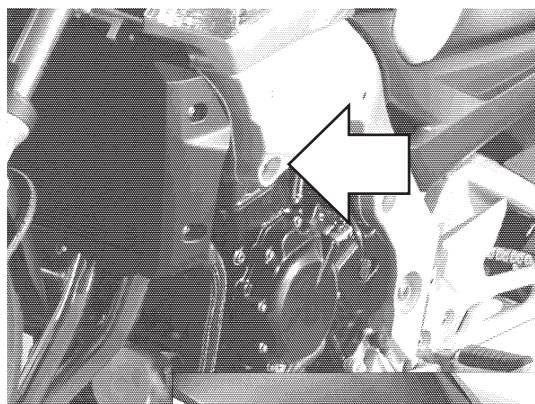

Assembly position (left side)



Assembly position (right side)

Assembly instructions

1. Remove the screws indicated with the arrows.
2. Replace the removed screws with the new screws (part #4), aluminium sleeve (part #3) and metal bars (parts #2) according to the attached drawing. Put the metal bars (parts #2) in the right positions according to the drawing.
3. Assemble the sliders and the screws according to the drawing (parts #1, #5, #6).
4. Assemble the screws #5 and the sliders with the metal bars #2.

We suggest to use the threadlocker to make sure that the screws do not get loose.

This product is entirely produced in the European Union. This product is a professional accessory to be used on the race track. Renner LTD takes no responsibility for any damages occurred despite of using protective accessories. For more information go to www.renner-moto.com

Assembly scheme (both sides)

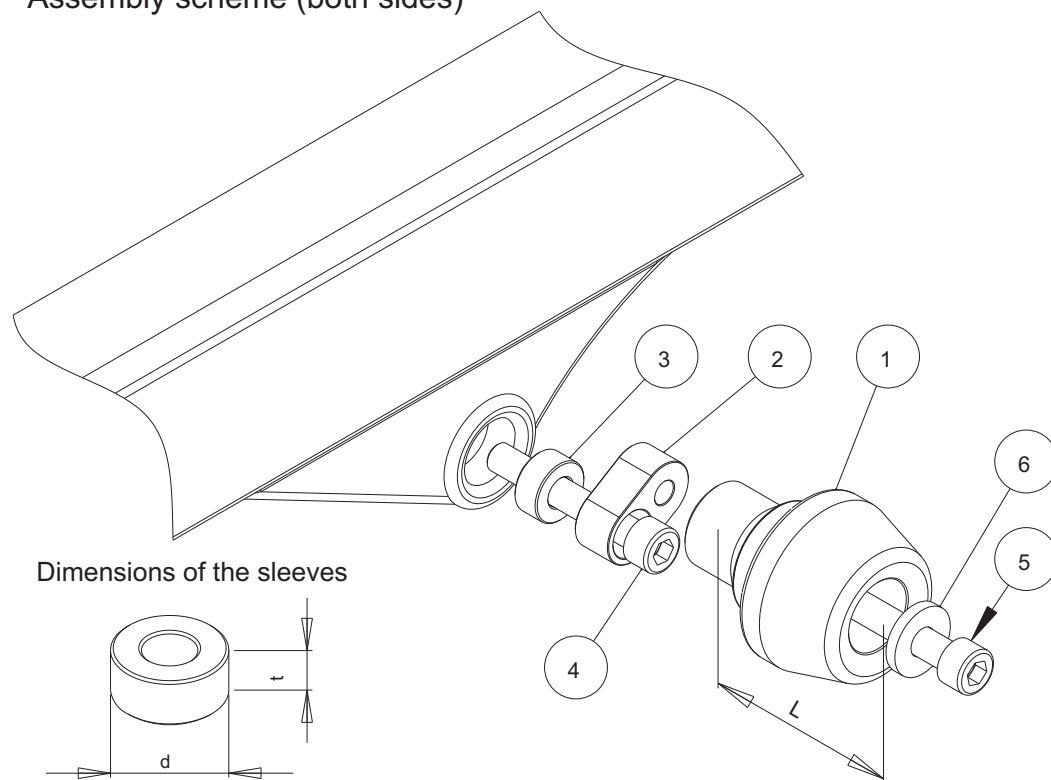

NO	PART	LEFT SIDE	RIGHT SIDE
1	Slider	L = 60 mm	L = 60 mm
2	Steel bar		
3	Sleeve	d=22 mm, t=25 mm	d=22 mm, t=20 mm
4	Screw	M10, l = 90 mm	M10, l = 70 mm
5	Screw	M10	M10
6	Washer		