

<p align="center">Protective sliders YAMAHA FZS 600 Fazer</p>
<p align="center">Year of production: - '03 Product code: 10411</p>

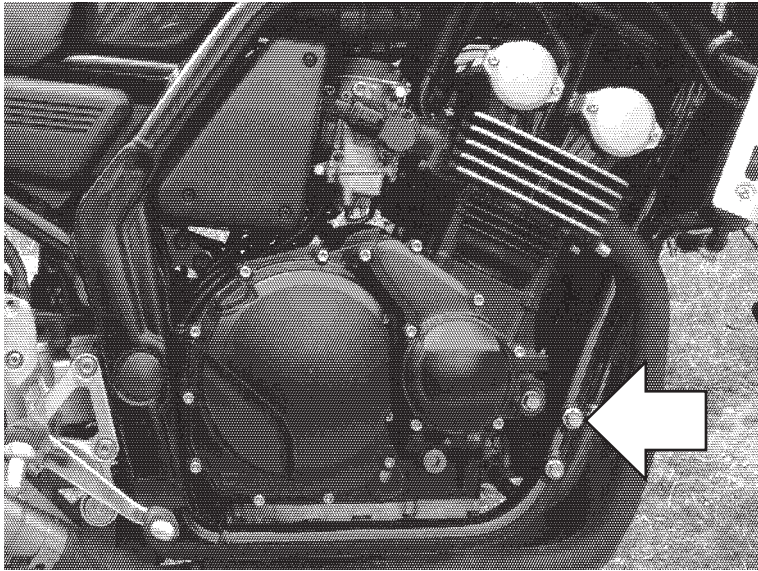

Assembly position
(both sides)

Assembly instructions

1. Remove the screws indicated with the arrows.
2. Replace the removed screws with the new screws (part #5), aluminium sleeve (part #4 - only on the right side), nuts (part #6) and metal bars (parts #3) according to the attached drawing. Put the metal bars (parts #2) in the right positions according to the drawing.
3. Assemble the sliders and the screws according to the drawing (parts #1, #2, #7, #8).
4. Assemble the screws #7 and the sliders with the metal bars #3.

We suggest to use the threadlocker to make sure that the screws do not get loose.

This product is entirely produced in the European Union. This product is a professional accessory to be used on the race track. Renner LTD takes no responsibility for any damages occurred despite of using protective accessories. For more information go to www.renner-moto.com

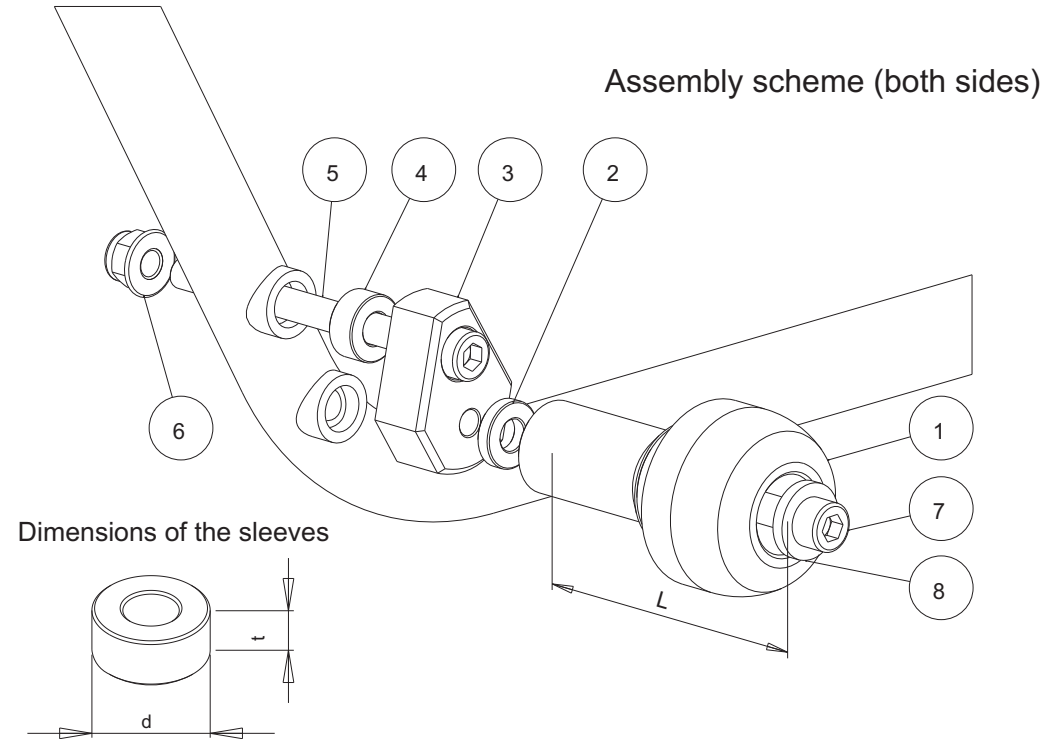

NO	PART	LEFT SIDE	RIGHT SIDE
1	Slider	L = 105 mm	L = 105 mm
2	Sleeve	d=20 mm, t=5 mm	d=20 mm, t=5 mm
3	Bar		
4	Sleeve	d=22 mm, t=10 mm	NOT IN THI SET
5	Screw	M10	M10
6	Nut	M10	M10
7	Screw	M10	M10
8	Washer		