

<b>Protective sliders</b> <b>YAMAHA FJR 1300</b> Year of production: '13-I Product code: 10430
---

Assembly scheme (both sides)

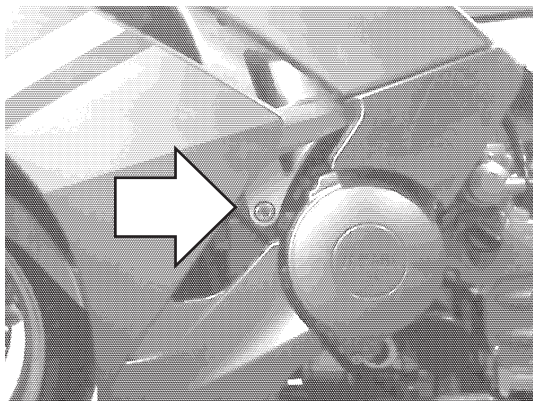

Assembly position (right side)

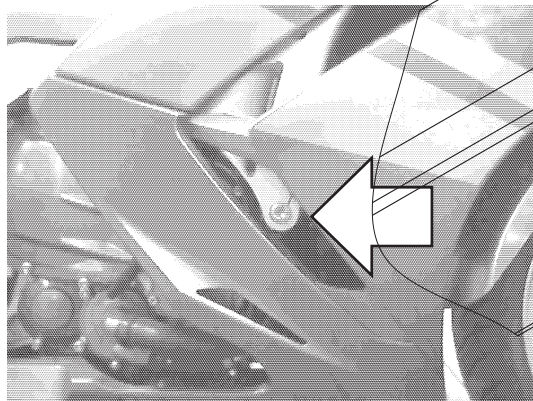

Assembly position (left side)

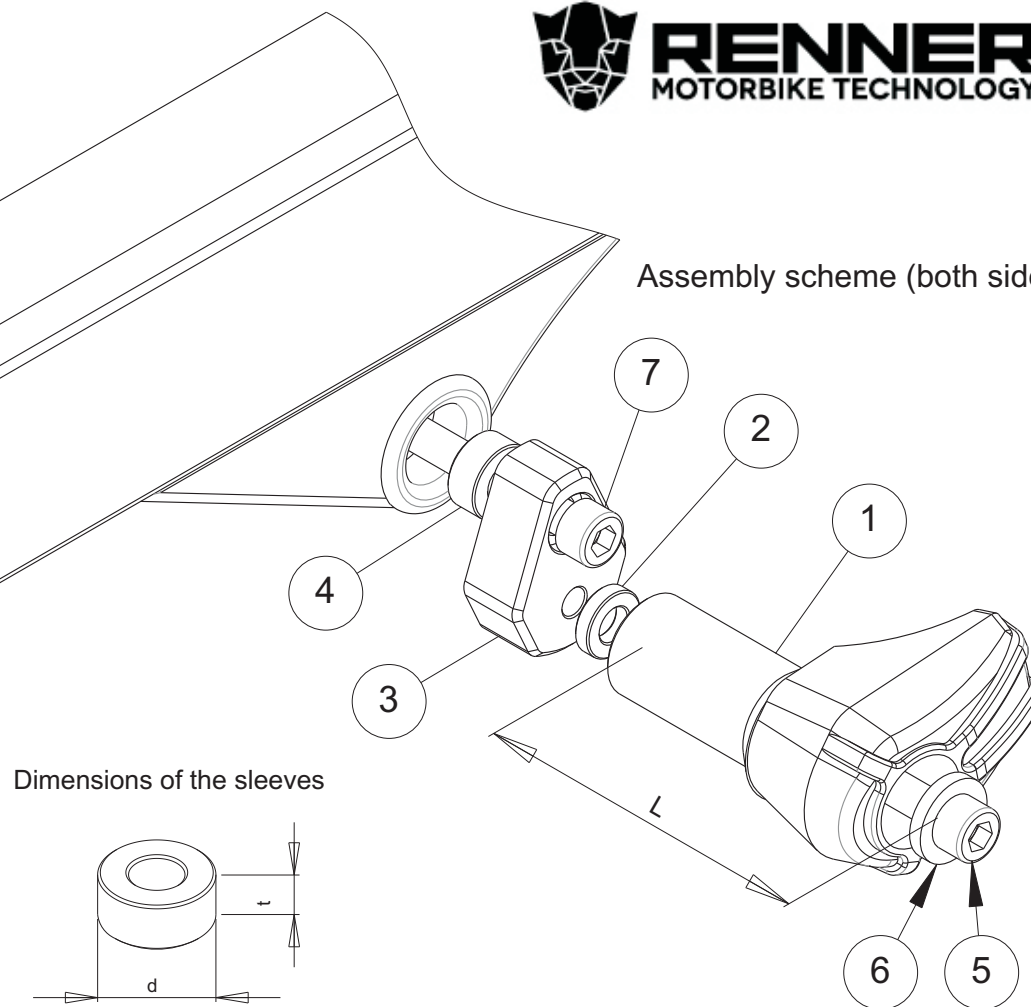

Dimensions of the sleeves

### Assembly instructions

1. Remove the fairings.
2. Remove the screws indicated by the arrow.
3. Replace the removed screws by the new screws (part #4), aluminium sleeves (part #3) and metal bars (part #2) according to the attached drawing. Put the metal bars (part #2) to the right positions according to the drawing.
4. Mark the positions of the holes on the fairings. The correct positions are opposite the threaded holes in the metal parts #2.
5. Drill the holes in the fairings. We suggest to drill small holes first (eg. 0,20" in diameter). Then check if the holes are in correct positions by putting the fairings on.
6. If the positions of the holes are correct, assemble the fairings.
7. Assemble the sliders, the screws and the washers (part #1, #5 and #6) according to the drawing. Put them into the second holes in part #2.

We suggest to use the threadlocker to make sure that the screws do not get loose.

This product is entirely produced in the European Union. This product is a professional accessory to be used on the race track. Renner LTD takes no responsibility for any damages occurred despite of using protective accessories. For more information go to [www.renner-moto.com](http://www.renner-moto.com)

NO	PART	LEFT SIDE	RIGHT SIDE
1	Slider	L = 90 mm	L = 90 mm
2	Sleeve	d=20 mm, t=5 mm	d=20 mm, t=5 mm
3	Bar		
4	Sleeve	d=20 mm, t=15 mm	d=20 mm, t=5 mm
5	Screw	M10	M10
6	Washer		
7	Screw	M12, l = 90 mm	M12, l = 80 mm